

# LITHIONICS BATTERY®

LITHIUM-ION IRON PHOSPHATE BATTERY SYSTEMS



MODEL NUMBER:  
**GTX12V315A-E2107-CS200**

Designed with Bluetooth® Wireless Monitoring,  
Internal Heater Kit, Aluminum Alloy Enclosure



INTERNAL BMS  
VERSION



Wireless Battery Monitoring via  
**Lithionics Battery® Monitor App**

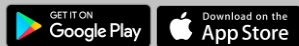

Application Note: Compatible with a Maximum Inverter Size of 3000 Watts. Do Not Connect to Larger Inverters or to Parallel-Connected Inverters.

Item	Description	
Model	GTX12V315A-E2107-CS200	
Nominal Voltage	12.8V	
Nominal Capacity	315Ah	
Nominal Watt Hours	4032Wh	
Internal Resistance	<3mΩ	
<b>Charge</b>		
Charging temperature range	32F/0C to 131F/55C	
Charge voltage	14.4V	
Recommended float charge voltage(for standby use)	13.4-13.6V	
Recommended charge current*	150A	
Maximum charge current*	200A	
<b>Discharge</b>		
Discharging temperature range	-4F/-20C to 131F/55C	
Operating Voltage Range	11.6-13.4V	
Recommended discharge current*	150A	
Maximum discharge current*	230A	
Pulse discharge current (1 second)	1200A	
Discharge cut-off voltage	NeverDie® Power Reserve @ 12.0V Low-Voltage Cut-Off @11.6V	
<b>Mechanical</b>		
Dimensions	Length 20.3" Width 6.6" Height 10.7"	
Mounting Orientation	Upright position only (terminals up)	
Weight	Approx. 68lbs (30.8kg)	
Terminal Bolt Size	M8-1.25x14mm	
<b>Storage</b>		
Storage Temperature & Humidity Range	< 1 Month	-4~95°F (-20~35°C), 45~75%RH
	< 3 Months	14~86°F (-10~30°C), 45~75%RH
	Recommended storage	59~95°F (15~35°C), 45%RH~75%RH
Long Term Storage	If the battery needs to be stored for > 3 months the voltage should be 13.2V (50%SOC), and stored at the recommended storage specifications shown above. Additionally, the battery needs at least one charge & discharge cycle every six months.	
Self-discharge rate	Residual capacity	≤3% per month; ≤15% per year
	Reversible capacity	≤1.5%per month; ≤8% per year

\* Maximum charging and discharging rates apply depending upon the ambient temperature and duty cycle of the system. UL1973 tests of maximum charge and discharge current were performed at 25°C/77°F



30% Smaller than 3 x 100Ah Group31  
Batteries, with Extra 15Ah to Spare

## INTERNAL NEVERDIE® BMS FEATURES

- NeverDie® Power Reserve (Spare Fuel) for Hotel Loads and Engine Cranking
- Over-Charge, Over-Discharge and Short-Circuit Protection (LVC, HVC, SCC)
- Low/High Temperature Charge/Discharge Protection
- Internal Heating Kit: Permits Charging as low as -20C/-4F
- Pushbutton On/Off switch for Safety and Storage
- Battery Gauge and Status Codes for Health Monitoring
- Bluetooth wireless telemetry with Lithionics Battery iOS and Android app
- CANbus telemetry in the RVIA RV-C format (M12)
- An alternator Field Control Circuit (FCC) (AMPSEAL8)
- Remote LED illuminated On/Off Power switch (AMPSEAL8)

ENERGY

315 AMP HOURS

PULSE AMPS: 1200 (1 SEC)

4032 WATT-HOURS

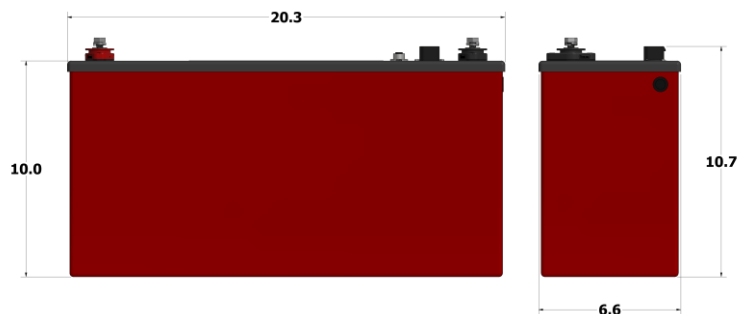

PART NUMBER:  
75-H1FBR-CS Ampseal 8 Harness Kit

EXTERNAL  
ACCESSORIES

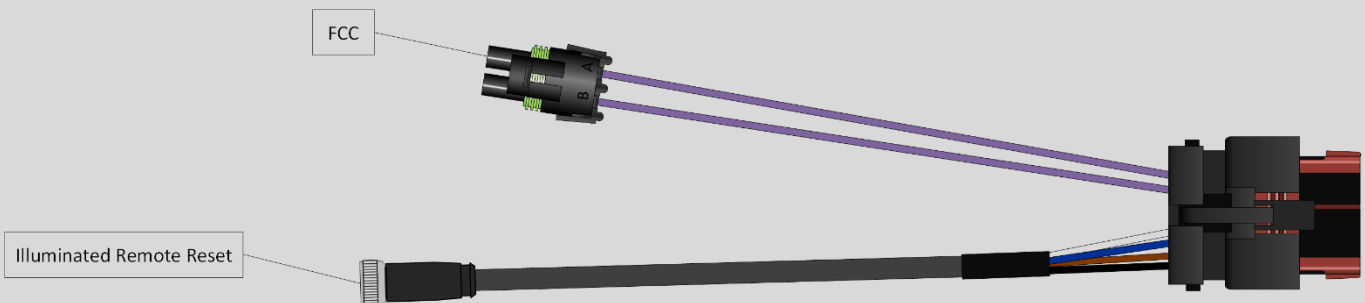

Feature	Description
<b>FCC</b>	Alternator Field Control Circuit
<b>Remote Reset Switch</b>	Illuminated Remote Momentary Power Switch

## ABOUT AMPSEAL 8

The mating Ampseal 8 connector kit is designed for use with any battery equipped with the NeverDie® Compact Series 200 Internal Battery Management System (BMS). The 8 pin Ampseal connector is located on the top of the battery and is used to access the BMS's ported features. This allows implementation of the combination of BMS functions listed above. Mating cable extensions are optional and available separately per the part numbers listed below.

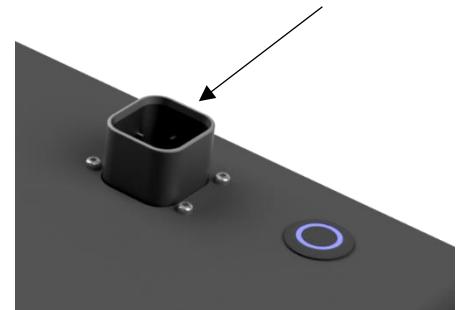

Optional Mating Extensions:		
Part Number	Model	Description
<b>75-149-180</b>	FCC Extension	Dual Weatherpack Connector to Bare Wires, 15ft Length
<b>75-224-196</b>	Illuminated Remote Reset	M8 Connector to Illuminated Remote Switch, 16ft Length

*Note: Contact factory regarding mating connections for CANBus feature.*